



 SWISS MADE  
SWISS TECHNOLOGY

**SERIES 530, 365, 330**  
MOISTURE ANALYZERS



## PRECISA DNA: ZERO COMPROMISE

Laboratory and industrial technicians are aware of the significance of the results they provide. That is why they are unwilling to accept any compromise in their field of work. This is precisely why leading specialists around the world place their trust in Precisa and have done for decades.

## PRECISA DNA: MOISTURE ANALYZER

Moisture Analyzers from Precisa - for efficient measurements and accurate results. As the leading manufacturer of thermogravimetric analytical equipment, Precisa excels with an extensive range of moisture analysis equipment, meeting highest demands in research, production and quality control.

## PRECISA DNA: SWISS PRECISION

Precisa products are prime examples of Swiss perfection and reliability. They are tried and tested in both demanding laboratory environments and industrial applications, and are subject to rigorous quality controls throughout the entire manufacturing process. Precisa invests continuously in developing new technologies and employs a highly qualified team. The result is a state-of-the-art range of precision instruments for the most exacting demands.



## HIGH PERFORMANCE

Moisture and water content have a defining influence on the quality and processing of materials, as well as on the price of raw materials and finished products in many industries including food, animal feeds, chemical and pharmaceutical products, construction materials etc.

The use of compact and robust precision moisture measuring instruments in the laboratory and in production increases efficiency and saves time and costs. Furthermore, productivity is enhanced by the fully automatic moisture analysis of samples, and the corresponding generation of measurement documentation. All models of the Series 530 PBM, 365 EM and 330 XM provide fast, error-free moisture analysis, using highest degrees of measurement performance and precision.

Simple to use and service-friendly to maintain, the Series 530 PBM, 365 EM and 330 XM are the results of Swiss precision in engineering and production, which guarantees reliability, robustness and an extensive life of error-free operation at highest levels of precision.

## SERIES 365

With model EM 120-HR, Precisa is setting new standards in the demanding area of high-end moisture analyzers.

The flagship model combines ease-of-use and sophisticated customizing features for advanced and demanding applications.

EM120-HR is an innovative, high-tech moisture analyzer which includes the latest technical developments. This flagship model contains unique performance features and a modern user- interface all within a compact form with a small footprint. Those users who will not accept any compromise in their working environment may enjoy the reassuring certainty that for many years they can rely on an extremely accurate instrument which features the latest technology and renowned Swiss quality.

## SERIES 530

Based on the 520 Series balances, our newest moisture analyzer range features the weighing technology PHASTbloc™ (Precisa Hybrid Advanced Sensor Technology) at its core. Developed using the latest simulation technologies high performance is being achieved to further expand the abilities of analyses.



# SERIES 530 PBM



Automated lid opening



Status indicator light; green, ready to use, red, analysis running

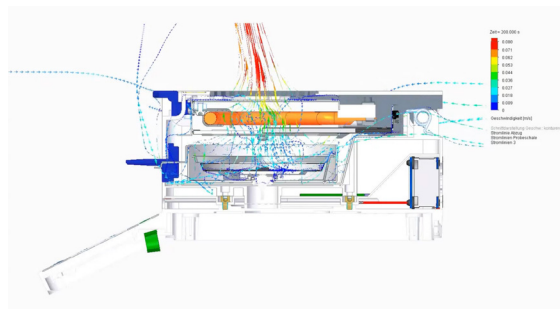

Thermodynamic software simulation of air-flow

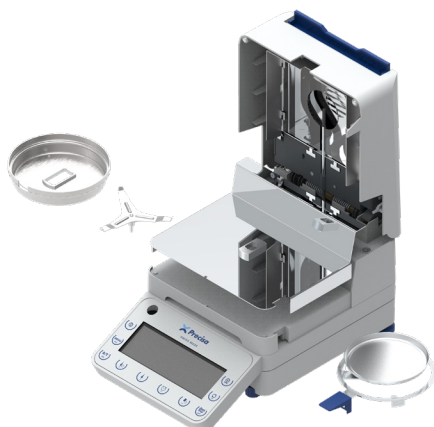

Hand disassemble of heating chamber for easy cleaning

## NEW FEATURES

### Automated Lid Opening

The 530 Series features an automated lid opening function which can be activated. After the sample run or at a selectable cool-down temperature, the lid will open automatically, for fast cooling down. This shortens and streamlines the process and frees resources of the users.

### Status Indication

The 530 Series comes with an LED status indicator. This helps the user to determine the status of the device regarding analysis and temperatures.

Green: Ready to use

Red: Analysis running

Red flashing: Device still hot

### Increased Performance

Using the latest state-of-the-art thermodynamic simulation software, our in-house R&D team created an end product with increased performance through reduction of air lifting effects. This allows the 530 series to analyze all samples with the highest precision and accuracy, even samples which contain a very low moisture content (e.g. polymers).

### Easy Cleaning

The flat and obstacle free surface of the 530 Series allows for a thorough and quick cleaning finish.

All the parts at the bottom of the heating chamber can be disassembled and re-assembled by hand, without the use of any tools. Cleaning of the parts removed can be done manually or with help of a dishwasher or ultrasonic cleaner.

### Unique PHASTbloc™ Technology

The heart of the 530 Series is the PHASTbloc™, the only hybrid weighing cell available on the market. PHASTbloc™ combines all of the benefits of a monolithic and conventional EMFC cell to ensure high performance and easy repairability.

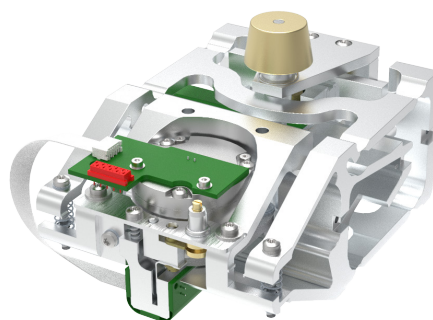

The PHASTbloc™ hybrid weighing cell

# SERIES 530 PBM



530 PBM Moisture Analyzer

## PRECISA PBM 60 / 60HR

### Readability 0.001 % / 0.01 %

High-end instruments for customers with a limited number of methods. These moisture analyzers are robust, provide a high degree of precision and are simple to operate.

Based on the latest 520 balance Series featuring the PHASTbloc™ technology the 530 Series is ideal for critical sample material e.g. with very low moisture content.

- Sturdy construction, perfect for laboratory and production environments
- Weighing range 124 g
- Readability up to 0.1mg / 0.001%
- High temperature range up to 230°C
- Temperature step of 1°C
- High-contrast LC display with backlight
- Memory storage of up to 30 methods
- USB type A (host), USB type B (device), RS232
- Choice of radiation heat source: halogen, infrared or infrared dark radiator
- Selectable heating modes: standard, boost, smooth

### Simple, Fast and Accurate

- Variety of start-up or end-point control selections for optimum control
- Language independent prompts operated by symbol keys
- Easy access sample holder

### Quality Assurance

- Results printed in GLP guideline format
- Numerical and statistical analysis available
- Real-time results shown in display
- Special version without glass for food industry



Choice of Radiation Heat Source



Large and Clear Backlit LCD Display

# SERIES 365



Compact and Modern Design



Choice of Radiation Heat Source



Graphic Display for Easy Guidance and Real Time Results.

## PRECISA EM 120-HR

### Readability 0.001 % / 0.01 %

The EM 120-HR instrument for fast and accurate moisture analysis with a wide range of methods; sophisticated and simple to operate, complying to the most stringent standards.

### Highly Precise Technology

- Weighing range 124 g
- Adjustable readability: 0.1 mg / 0.001 % and 1 mg / 0.01 %
- High temperature range up to 230°C
- Automatic self calibration system (SCS)
- Bright graphic display
- Extended memory capacity, 100 methods
- Choice of radiation heat source: halogen, infrared, infrared dark radiator
- USB and RS232 interfaces as standard
- Selectable heating modes: standard, boost, smooth

### Intuitive User Interface

- Freely programmable display
- Graphic presentation of the analysis
- Choice of auto stop criteria settings

### Quality Assurance

- Compliance with GLP and GMP
- Numerical and statistical analysis available
- Real-time observation of analysis

### Versatile Connectivity

Advanced slide-in module technology: USB Host, Ethernet wired, Ethernet wireless, Bluetooth and others.

# SERIES 330



Robust and Simple to Operate



Easy Sample Access



Menu-driven, Screen-guided Applications

## PRECISA XM 66 / XM 50

### Readability 0.01 %

High-end units for customers with limited number of methods. These instruments are robust, provide a high degree of precision and are simple to operate.

### The Versatile All-Round Moisture Determination Solution

- Sturdy construction, perfect for all laboratory and production environments
- Weighing range up to 310 g
- Readability up to 1 mg / 0.001%
- High temperature range up to 230°C
- Temperature step of 1°C
- High contrast, bright vacuum fluorescent display
- Memory storage of up to 30 methods
- Interface RS232
- Choice of radiation heat source: halogen, infrared, infrared dark radiator
- Selectable heating modes: standard, boost, smooth

### Simple, Fast and Accurate

- Variety of start-up and end-point control selections for optimum control
- Language independent prompts operated by symbol keys
- Easy access sample holder

### Quality Assurance

- Results printed in GLP guideline format
- Numerical and statistical analysis available
- Real-time results shown in display
- Special version without glass for the food industry
- XM 66 with increased weighing range of 310 g and special software for the rapid moisture results for sewage and waste water treatment plants
- XM50 the all-rounder for low weight samples and single method use

# MODELS

## SERIES 530

Model	Capacity	Readability	Repeatability	Linearity	Temperature Range	Pan Size (mm)	Response Time
PBM 60	124 g	1 mg / 0.01%	2 g / 0.1 % 10 g / 0.02 %	1.5 mg	50 - 230°C	∅ 100	3 s
PBM 60-HR	124 g	0.1 mg / 0.001%	2 g / 0.05 % 10 g / 0.01 %	1.5 mg	50 - 230°C	∅ 100	4 s

## SERIES 365

Model	Capacity	Readability	Repeatability	Linearity	Temperature Range	Pan Size (mm)	Response Time
EM 120-HR	124 g	0.1 mg / 0.001%	2 g / 0.1 % 10 g / 0.01 %	0.2 mg	50 - 230°C	∅ 100	4 s

## SERIES 330

Model	Capacity	Readability	Repeatability	Linearity	Temperature Range	Pan Size (mm)	Response Time
XM 66	310 g	1 mg / 0.01 %	2 g / 0.2 % 10 g / 0.02 %	1.5 mg	50 - 230°C	∅ 100	3 s
XM 50	52 g	1 mg / 0.01%	2 g / 0.5 % 10 g / 0.05 %	3.0 mg	50 - 170°C	∅ 100	3 s

## PRODUCT SPECIFICATIONS

Model	Dimensions (WxLxH)	Net Weight (kg)
PBM Models	201 x 333 x 177 mm	5.5
XM Models	218 x 340 x 177 mm	6.2
EM Models	240 x 380 x 177 mm	6.7

## ITEM NUMBERS\*

Radiator	EM 120-HR	PBM 60-HR	PBM 60	XM 50
Halogen radiator, 230 V	365-9245-001	530-9243-001	530-9324-001	335-9360B-001
Halogen radiator, 115 V	365-9245-002	530-9243-002	530-9324-002	335-9360B-002
Infrared radiator, 230 V	365-9245-003	530-9243-003	530-9324-003	335-9360B-003
Infrared radiator, 115 V	365-9245-004	530-9243-004	530-9324-004	335-9360B-004
Infrared dark radiator, 230 V	365-9245-007	530-9243-007	530-9324-007	335-9360B-007
Infrared dark radiator, 115 V	365-9245-008	530-9243-008	530-9324-008	335-9360B-008

\* The item numbers include the moisture analyzer with the corresponding heating source



# OPTIONS & ACCESSORIES

Accessories	PBM 60	PBM 60-HR	EM 120-HR	XM 60-HR	XM 60	XM 66	XM 50
Sample pans, aluminum, with collar Ø 100 mm, set of 80 pieces	350-1015	350-1015	350-1015	350-1015	350-1015	350-1015	350-1015
Sample pans, aluminum, Ø 100mm, set of 80 pieces	–	–	350-2032	350-2032	350-2032	350-2032	350-2032
Sample pan reusable, stainless steel, Ø100mm, 1 piece	330-2018	330-2018	330-2018	330-2018	330-2018	330-2018	330-2018
Fiberglass filters, Ø 90mm, set of 100 pieces	350-4130	350-4130	350-4130	350-4130	350-4130	350-4130	350-4130
Temperature calibration disc, sensor - type K	350-8580	350-8580	350-8580	350-8580	350-8580	350-8580	350-8580
Temperature calibration set, with certificate	350-8585	350-8585	350-8585	350-8585	350-8585	350-8585	350-8585
Temperature calibration set, without certificate	350-8584	350-8485	350-8584	350-8584	350-8584	350-8584	350-8584
Calibration weight, 50 g, E2	350-8241	350-8241	350-8241	350-8241	350-8241	350-8241	350-8241
Dust filter set for moisture analyzers	350-8687	350-8687	350-8687	350-8687	350-8687	350-8687	350-8687
Protective cover 530 for terminal, set of 5 pieces	–	–	–	–	–	–	–

Slide-in Modules, on demand only	EM 120-HR
USB Host	350-8665
LAN Ethernet connection	350-8666
WiFi connection	350-8667
Bluetooth connection	350-8668
PS 2 female & RS232 DB9 female	350-8670

Operating Temperature	Line Voltage, Tolerance	Power Consumption	Frequency
10°C - 35°C (50°F - 95°F)	115V / 230V, -15% / +10%	450 W	50 - 60 Hz

# SPECIAL PRODUCTS ACCESSORIES

Common Accessories	PBM 60/-HR	330/335 XM	365 EM
Printer LP4024, 230V / 115V	350-8391	350-8391	350-8391
Bluetooth connection for Printer LP4024	350-8391-001	350-8391-001	350-8391-002
Paper roll for Printer LP4024, set of 4 pieces	350-8392	350-8392	350-8392
Adhesive paper roll for Printer LP4024, set of 5 pieces	350-8396	350-8396	350-8396
Ribbon for Printer LP4024	PN 3953-013	PN 3953-013	PN 3953-013
Multiplexor for up to 7 instruments for serial (RS232) data transmission to PC or Printer (at least one instrument must be a series 320, 321, 330, 365 or 490)	-	350-8513	350-8513
Data cable RJ45, 0.75m	-	350-8525	-
Data cable RJ45, 1.5m	-	350-8520	-
Data cable RJ45, 3m	-	350-8521	-
Adapter RJ45-DB9f, (PC/Printer LP4024)	-	350-8522	-
Data cable RJ45-DB9f, 1.5m, (PC/Printer LP4024)	-	350-8557	-
Data cable DB9m-DB9f, 1.5m, (PC/Printer LP 4024, 1:1)	350-8672	-	350-8672
USB cable A-B, 1.5m, (PC)	PN 3950-125	-	PN 3950-125
Interface box	350-8940-000	350-8940-000	350-8940-000
Interface box, LAN Ethernet connection	350-8940-001	350-8940-001	350-8940-001
Interface box, WiFi connection	350-8940-002	350-8940-002	350-8940-002
Interface box, Bluetooth connection	350-8940-003	350-8940-003	350-8940-003
Anti-theft device, mechanical	350-8555	350-8555	350-8555

PrecisaBUS Accessories (available on demand only)	PBM 60/-HR	330/335 XM	365 EM
Remote display free-standing, incl. 1.5 m cable	350-8401-001	350-8504	-
Remote display with wall bracket, incl. 1.5 m cable	350-8401-002	350-8516	-
RS232 interface box for data transmission, DB25f: - to PC, Printer or Barcode-Printer - from Barcode-Reader (350-8856) or reference balance	-	350-8506	-
Interface 20mA current loop passive	-	350-8526	-
LAN Ethernet connection	-	350-8573	-
WiFi connection	-	350-8588	-
Input / Output module with 6 TTL inputs / 8 relay outputs	-	350-8509	-

# TECHNICAL SPECIFICATIONS

















Model	PBM 60	PBM 60-HR	EM 120-HR	XM 50
<b>Heat Source</b>				
Radiator type	Halogen / Infrared / Dark	Halogen / Infrared / Dark	Halogen / Infrared / Dark	Halogen / Infrared / Dark
<b>Weighing system</b>				
Weighing range (g)	124	124	124	52
Pan Size (∅ mm)	100	100	100	100
Smallest sample weight (g)	0.2	0.2	0.2	0.2
Readability (g)	0.001	0.0001	0.0001	0.001
Response time (s)	3 s	4 s	4 s	4 s
<b>Moisture Analysis</b>				
Readability (%)	0.01	0.001	0.001	0.01
<b>Repeatability (%)</b>				
at approx ... g / ...%	2 / 0.1	2 / 0.1	2 / 0.1	2 / 0.5
at approx ... g / ...%	10 / 0.02	10 / 0.01	10 / 0.01	10 / 0.05
<b>Results calculations</b>				
100% ... 0%	✓	✓	✓	✓
0% ... 100%	✓	✓	✓	✓
ATRO 100% ... 999%	✓	✓	✓	✓
ATRO 0% ... 999%	✓	✓	✓	✓
g/kg	✓	✓	✓	✓
Residual weight (g)	✓	✓	✓	✓
Weight loss (g)	✓	✓	✓	✓
<b>Heating</b>				
Temperature range / Step (°C)	50 - 230 / 1	50 - 230 / 1	50 - 230 / 1	50 - 170 / 1
Intervals	boost + 1	boost + 1	3	boost + 1
Heating modes	standard, boost, smooth	standard, boost, smooth	standard, boost, smooth, step	standard, boost, smooth
Interval Switch-off (min)			0.1 - 99.9	
Interval Switch-off (%)			0.1 - 99.9	
<b>Switch-off Criteria</b>				
Auto Stop (d/s)	freely definable	freely definable	freely definable	freely definable
Auto Stop (%/s)	freely definable	freely definable	freely definable	
Timer Stop (min)	1 - 240	0.1 - 240	0.1 - 240	0.1 - 240
Minimum Stop (%)			0.1 - 99.9	
AdaptStop	✓	✓	✓	✓
<b>Sequence control system:</b>				
Weight loss / Residual weight	✓	✓	✓	✓
Semi automatic standby temperature (°C)	40 - 100	40 - 100	40 - 100	40 - 100
<b>Monitoring:</b>				
Inspection window		✓	✓	✓
Buzzer	✓	✓	✓	✓
<b>Print-out:</b>				
GLP	✓	✓	✓	✓
Print interval (min)	0.1 - 10.0	0.1 - 10.0	0.1 - 10.0	0.1 - 10.0
User texts			✓	
Freely definable formats			✓	
Sample numbering	✓	✓	✓	✓

# TECHNICAL SPECIFICATIONS

Model	PBM 60	PBM 60-HR	EM 120-HR	XM 50
<b>Memory Capacity</b>				
Methods	30	30	100	1
User texts			20	
<b>Operation</b>				
Display	LCD, backlit	LCD, backlit	Graphics, LCD, backlit	VFD, 20 characters, alphanumerical
Keyboard	10 keys	10 keys	12 keys	10 keys
Menu controlled	✓	✓	✓	✓
Sample feed	manual	manual	manual	manual
Password protection	✓	✓	✓	✓
<b>Special Features</b>				
Weighing-in guidance	✓	✓	✓	✓
Statistics	✓	✓	✓	✓
Remote control (heater)	✓	✓	✓	✓
Ash residue	✓	✓	✓	
<b>Calibration</b>				
Balance	external	external	internal	external
Temperature	100°C and 160°C, selectable	100°C and 160°C, selectable	100°C and 160°C, selectable	100°C and 160°C, selectable
<b>Miscellaneous</b>				
Clock for date and time	✓	✓	✓	✓
PC / Printer interface	USB (PC), RS232	USB (PC), RS 232	USB (PC), RS232	RS 232
Anti-theft protection	code and mechanical	code and mechanical	code and mechanical	code and mechanical



# FEATURES & APPLICATIONS

Features	PBM 60	PBM 60-HR	EM 120-HR	XM 50
 Swiss Made	✓	✓	✓	✓
 Backlit Graphic LCD			✓	
 Backlit LCD	✓			
 Vacuum Fluorescent Display		✓		✓
 Self-calibration system, fully automated			✓	
 External Calibration, with calibration warning	✓	✓		✓
 Clock (printout GLP/GMP, auto-cal etc.)	✓	✓	✓	✓
 USB device (for PC)	✓		✓	
 Ethernet connection	<b>AC</b>		<b>AC</b>	
 Wi-Fi connection	<b>AC</b>		<b>AC</b>	
 Bluetooth connection	<b>AC</b>		<b>AC</b>	
 USB host (barcode, flash drive, ...)	✓		<b>AC</b>	
 USB B device	✓			
 Support IQ/OQ/PQ	✓	✓	✓	✓
 Anti-theft protection (mechanical and code)	✓	✓	✓	✓
 Easy alphanumeric input			✓	
 RS232 interface (for PC/printer)	✓	✓	✓	✓

Applications	PBM 60	EM 120-HR	XM 60-HR	XM 50
 Automatic repeatability test		✓		
 Statistics	✓	✓	✓	✓
 Check weighing	✓	✓	✓	✓

# DIMENSIONS

## SERIES 530

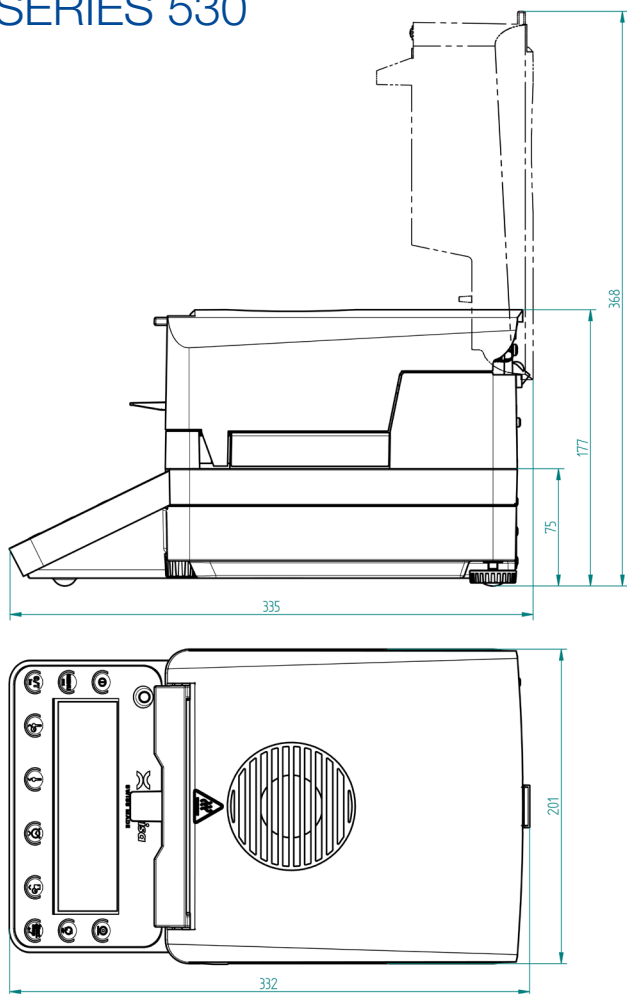

## SERIES 330

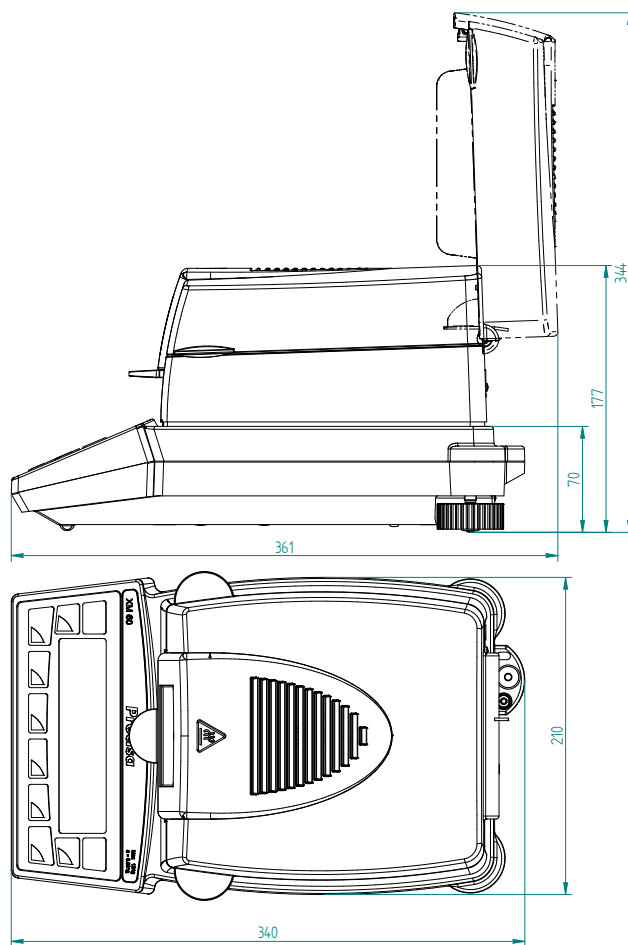

# DIMENSIONS

## SERIES 365

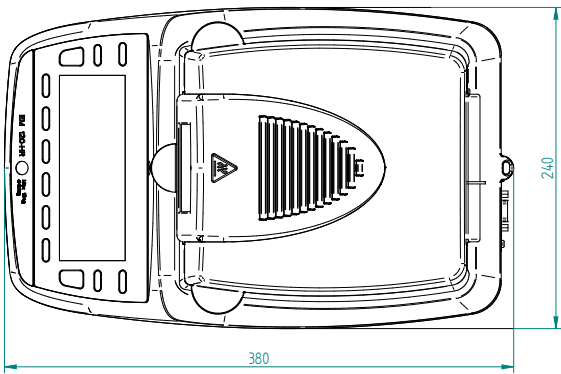
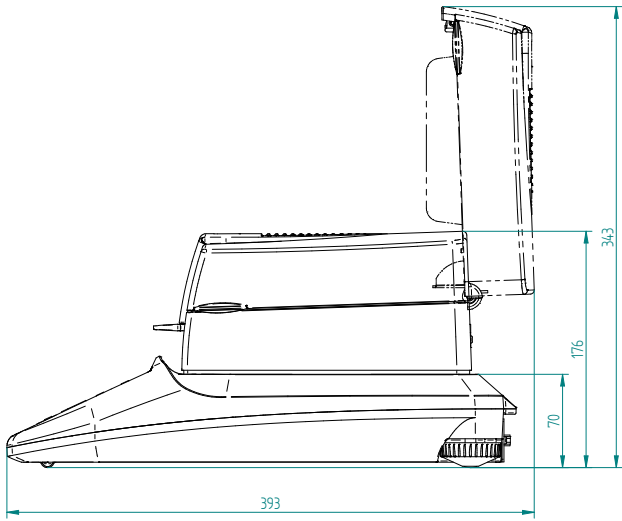

# TECHCOMP GROUP

In addition to Precisa, Techcomp Europe comprises of the following companies:



## Precisa Gravimetrics AG

Moosmattstrasse 32  
8953 Dietikon, Switzerland  
Tel. +41 44 744 28 28  
Fax +41 44 744 28 38  
Email: [info@precisa.ch](mailto:info@precisa.ch)  
[www.precisa.com](http://www.precisa.com)

ISO 9001  
BUREAU VERITAS  
Certification

N°CH4638370

